



15 Kenton Lands Road, Erlanger, Kentucky 41018 - Ph# 859-341-5500 - Fax# 859-341-4115

SCHLAGE KEYPAD DEADBOLTS

Features and Benefits

- Innovative Turn Lock feature allows you to lock & leave without a key
- Provides the convenience of keyless access; customizable to fit your security needs
- Ideal for front doors, side & back doors, garage entry doors, etc.
- Easily replace most existing deadbolts with a screwdriver in about 30 minutes
- No programming required; preset with two user codes so it's ready to use right out of the box



BE365 PLY 619 Satin Nickel



BE365 PLY 716 Aged Bronze

DEADBOLTS

| | CASE QTY | 619 | CODE | 716 | CODE |
|---------------|----------|-----------------|-------------|-----------------|-------------|
| BE365 PLY 619 | | \$272.00 | 59-21-19665 | \$272.00 | 59-21-16665 |



BE365 CAM 619 Satin Nickel



BE365 CAM 716 Aged Bronze

DEADBOLTS

| | CASE QTY | 619 | CODE | 716 | CODE |
|-----------|----------|-----------------|-------------|-----------------|-------------|
| BE365 CAM | | \$272.00 | 59-21-19165 | \$272.00 | 59-21-16165 |

* PRICES ARE SUBJECT TO CHANGE WITHOUT NOTICE *



**DYKE
INDUSTRIES
Inc.**

**SECTION E
SCHLAGE LOCKS**

15 Kenton Lands Road, Erlanger, Kentucky 41018 - Ph# 859-341-5500 - Fax# 859-341-4115

SCHLAGE LOCKS LIST

KNOBS

| PLYMOUTH | | CASE QTY | 605 | CODE | 619 | CODE |
|-----------------|----------|-----------------|------------|-------------|------------|-------------|
| F 10 | PASSAGE | 20 | \$29.00 | 596405110 | \$35.00 | 596419110 |
| F 40 | PRIVACY | 20 | \$33.00 | 596405140 | \$38.00 | 596419140 |
| F 51(KA4) | ENTRY | 20 | \$56.00 | 596405151 | \$60.00 | 596419151 |
| F 170 | DUMMY | 30 | \$13.00 | 596405170 | \$15.00 | 596419170 |
| F 359 | INT TRIM | 20 | \$88.00 | 597405159 | \$94.00 | 597419159 |
| ORBIT | | CASE QTY | 605 | CODE | 626 | CODE |
| F 10 | PASSAGE | 20 | \$37.00 | 596305110 | \$43.00 | 596326110 |
| F 40 | PRIVACY | 20 | \$39.00 | 596305140 | \$48.00 | 596326140 |
| F 51(KA4) | ENTRY | 20 | \$61.00 | 596305151 | \$70.00 | 596326151 |
| F 170 | DUMMY | 30 | \$16.00 | 596305170 | \$18.00 | 596326170 |
| GEORGIAN | | CASE QTY | 605 | CODE | 609 | CODE |
| F 10 | PASSAGE | 20 | \$30.00 | 596205110 | \$33.00 | 596209110 |
| F 40 | PRIVACY | 20 | \$34.00 | 596205140 | \$37.00 | 596209140 |
| F 51(KA4) | ENTRY | 20 | \$54.00 | 596205151 | \$59.00 | 596209151 |
| F 170 | DUMMY | 30 | \$13.00 | 596205170 | \$15.00 | 596209170 |
| F 359 | INT TRIM | 20 | \$90.00 | 597405259 | \$92.00 | 596209159 |
| LEVERS | | | | | | |
| ACCENT | | CASE QTY | 605 | CODE | 613 | CODE |
| F 10 | PASSAGE | 20 | \$51.00 | 595805X10 | \$59.00 | 595813X10 |
| F 40 | PRIVACY | 20 | \$55.00 | 595805X40 | \$64.00 | 595813X40 |
| F 51(KA4) | ENTRY | 20 | \$105.00 | 595805X51 | \$121.00 | 595813X51 |
| F 170 | DUMMY | 30 | \$23.00 | 595805X70 | \$26.00 | 595813X70 |
| F 359 | INT TRIM | 20 | \$104.00 | 595805X59 | \$120.00 | 595813X59 |
| ACCENT | | CASE QTY | 619 | CODE | | |
| F 10 | PASSAGE | 20 | \$59.00 | 595819110 | | |
| F 40 | PRIVACY | 20 | \$64.00 | 595819X 40 | | |
| F 51(KA4) | ENTRY | 20 | \$121.00 | 595819X 51 | | |
| F 170 | DUMMY | 30 | \$26.00 | 595819X 70 | | |
| F 359 | INT TRIM | 20 | \$120.00 | 595819X 59 | | |
| FLAIR | | CASE QTY | 605 | CODE | 626 | CODE |
| F 10 | PASSAGE | 20 | \$50.00 | 596805X10 | \$58.00 | 596826X10 |
| F 40 | PRIVACY | 20 | \$54.00 | 596805X40 | \$62.00 | 596826X40 |
| F 51(KA4) | ENTRY | 20 | \$103.00 | 596805X51 | \$118.00 | 596826X51 |
| F 170 | DUMMY | 30 | \$22.00 | 596805X70 | \$26.00 | 596826X70 |
| F 359 LH | INT TRIM | 20 | \$102.00 | 597405659 | \$117.00 | 596826159 |
| F 359 RH | INT TRIM | 20 | \$102.00 | 597405759 | \$117.00 | 596826259 |

X=1=LEFT HAND X=2=RIGHT HAND

* PRICES ARE SUBJECT TO CHANGE WITHOUT NOTICE *



**DYKE
INDUSTRIES
Inc.**

**SECTION E
SCHLAGE LOCKS**

15 Kenton Lands Road, Erlanger, Kentucky 41018 - Ph# 859-341-5500 - Fax# 859-341-4115

SCHLAGE LOCKS

DEADBOLTS

| | CASE QTY | 605 | CODE | 609 | CODE |
|---------------------|----------|---------|-----------|---------|-----------|
| BR 260 SGL CYLINDER | 20 | \$47.00 | 592005260 | \$51.00 | 592009260 |
| | CASE QTY | 626 | CODE | | |
| BR 260 SGL CYLINDER | 20 | \$53.00 | 592026260 | | |

| | CASE QTY | 613 | CODE | 619 | CODE |
|------------------|----------|---------|-----------|---------|-----------|
| B 360 N CYLINDER | 20 | \$64.00 | 592013160 | \$64.00 | 592019360 |

| | CASE QTY | 605 | CODE | 619 | CODE |
|-------------------------|----------|----------|-----------|----------|-----------|
| F 358 SGL CAMELOT | 4 | \$154.00 | 596105158 | \$195.00 | 596119158 |
| F 358 SGL BOWMAN | 4 | \$154.00 | 597405358 | | |
| | | | | 609 | CODE |
| F 360 V PARTHENON / GEO | 4 | | | \$262.00 | 597509360 |

| | CASE QTY | 605 | CODE | 609 | CODE |
|--------------------|----------|----------|-----------|----------|-----------|
| F 358 SGL PLYMOUTH | 4 | \$147.00 | 597405158 | \$161.00 | 597409158 |
| | CASE QTY | 613 | CODE | 619 | CODE |
| F 358 SGL PLYMOUTH | 4 | \$186.00 | 597413158 | \$186.00 | 597419158 |
| | CASE QTY | 626 | CODE | | |
| F 358 SGL PLYMOUTH | 4 | \$186.00 | 596426158 | | |

SLIDING DOOR LOOKS

| | CASE QTY | 605 | CODE |
|---------|----------|---------|-----------|
| PASSAGE | 20 | \$21.00 | 592205110 |
| PRIVACY | 20 | \$34.00 | 592205101 |

* PRICES ARE SUBJECT TO CHANGE WITHOUT NOTICE *



DYKE
INDUSTRIES
Inc.

SECTION E
DEXTER LOCKS

15 Kenton Lands Road, Erlanger, Kentucky 41018 - Ph# 859-341-5500 - Fax# 859-341-4115

DEXTER LOCKS LIST



Dover Lever in Bright Brass, Hall/Closet, J10 DOV 605

LEVERS

| LEVERS 605 | PER BOX | LIST PRICE | CODE |
|----------------------------|----------------|-------------------|-------------|
| J 10 605 DOVER PASSAGE | 24 | \$53.00 | 59-15-05110 |
| J 40 605 DOVER PRIVACY | 24 | \$40.00 | 59-15-05140 |
| J 54 605 DOVER KEYED ENTRY | 24 | \$37.00 | 59-15-05154 |
| J 170 605 DOVER DUMMY | 24 | \$16.00 | 59-15-05170 |

LEVERS

| LEVERS 630 | PER BOX | LIST PRICE | CODE |
|----------------------------|----------------|-------------------|-------------|
| J 10 630 DOVER PASSAGE | 24 | \$55.00 | 59-15-30110 |
| J 40 630 DOVER PRIVACY | 24 | \$41.00 | 59-15-30140 |
| J 54 630 DOVER KEYED ENTRY | 24 | \$39.00 | 59-15-30154 |
| J 170 630 DOVER DUMMY | 24 | \$17.00 | 59-15-30170 |

* PRICES ARE SUBJECT TO CHANGE WITHOUT NOTICE *



**DYKE
INDUSTRIES
Inc.**

SECTION E

DEXTER LOCKS

15 Kenton Lands Road, Erlanger, Kentucky 41018 - Ph# 859-341-5500 - Fax# 859-341-4115

DEXTER LOCKS LIST

LEVERS

| LEVERS 605 | PER BOX | LIST PRICE | CODE |
|------------------------------|---------|------------|-----------|
| JH 60 BAR 605 LAS | 4 | \$153.00 | 598405X60 |
| J 10 605 LASALLE PASSAGE | 24 | \$38.00 | 598405X10 |
| J 40 605 LASALLE PRIVACY | 24 | \$40.00 | 598405X40 |
| J 54 605 LASALLE KEYED ENTRY | 24 | \$53.00 | 598405X54 |
| J 170 605 LASALLE DUMMY | 50 | \$16.00 | 598405X70 |

X=1=LEFT HAND X=2=RIGHT HAND

| | PER BOX | 605 LIST | CODE | 630 LIST | CODE |
|------------------------|---------|----------|-----------|----------|-----------|
| JD 60 SINGLE DEAD BOLT | 24 | \$30.00 | 598605160 | \$31.00 | 598630160 |

KNOBS

| | PER BOX | 605 LIST | CODE | 630 LIST | CODE |
|-------------------------|---------|----------|-----------|----------|-----------|
| JH 60 BAR/ CNA | 4 | \$143.00 | 598205160 | \$151.00 | 598230160 |
| J 10 CORONA PASSAGE | 24 | \$21.00 | 598205110 | \$22.00 | 598230110 |
| J 40 CORONA PRIVACY | 24 | \$23.00 | 598205140 | \$25.00 | 598230140 |
| J 54 CORONA KEYED ENTRY | 24 | \$30.00 | 598205154 | \$32.00 | 598230154 |
| J 170 CORONA DUMMY | 50 | \$9.00 | 598205170 | \$8.00 | 598230170 |
| JH 60 BAR/ BYR | 4 | \$141.00 | 598105160 | \$151.00 | 598130160 |
| J 10 BYRON PASSAGE | 24 | \$18.00 | 598105110 | \$19.00 | 598130110 |
| J 40 BYRON PRIVACY | 24 | \$20.00 | 598105140 | \$21.00 | 598130140 |
| J 54 BYRON KEYED ENTRY | 24 | \$27.00 | 598105154 | \$28.00 | 598130154 |
| J 170 BYRON DUMMY | 50 | \$8.00 | 598105170 | \$8.00 | 598130170 |

* PRICES ARE SUBJECT TO CHANGE WITHOUT NOTICE *



15 Kenton Lands Road, Erlanger, Kentucky 41018 - Ph# 859-341-5500 - Fax# 859-341-4115

1700 SERIES FOLDING DOOR HARDWARE SYSTEM



| CODE | DESCRIPTION | WIDTH | EACH |
|-------------|-------------|-------|---------|
| 61-12-00172 | 24" 2-DOOR | 24" | \$21.20 |
| 61-12-00171 | 30" 2-DOOR | 30" | \$22.00 |
| 61-12-00173 | 36" 2-DOOR | 36" | \$23.00 |
| 61-12-00174 | 48" 4-DOOR | 48" | \$42.00 |
| 61-12-00175 | 60" 4-DOOR | 60" | \$44.00 |
| 61-12-00176 | 72" 4-DOOR | 72" | \$48.00 |

2200 SERIES SLIDING DOOR HARDWARE SYSTEM

| CODE | DESCRIPTION | HEIGHT | WIDTH | HEIGHT | WIDTH | EACH |
|-------------|-------------|-------------|-------------|-----------|---------|---------|
| 61-12-00204 | 48" 2-DOOR | DH + 3 1/2" | 2XDW+1-1/4" | 6' 9 3/4" | 47 1/4" | \$26.00 |
| 61-12-00205 | 60" 2-DOOR | DH + 3 1/2" | 2XDW+1-1/4" | 6' 9 3/4" | 59 1/4" | \$29.00 |
| 61-12-00206 | 72" 2-DOOR | DH + 3 1/2" | 2XDW+1-1/4" | 6' 9 3/4" | 71 1/4" | \$34.00 |
| 61-12-00208 | 96" 4-DOOR | DH + 3 1/2" | 4XDW+1-1/4" | 6' 9 3/4" | 94 1/2" | \$58.00 |

* PRICES ARE SUBJECT TO CHANGE WITHOUT NOTICE *



**2202-F SLIDING DOOR HARDWARE
ALUMINUM TRACK WITH FASCIA FOR 1 3/8" DOORS**

| CODE | DESCRIPTION | ROUGH OPENING | | FINISHED OPENING | | EACH |
|-------------|-------------|---------------|-------------|------------------|---------|---------|
| | | HEIGHT | WIDTH | HEIGHT | WIDTH | |
| 61-12-02224 | 48" 2-DOOR | DH + 3 1/2" | 2XDW+1-1/4" | 6' 9 3/4" | 47 1/4" | \$38.00 |
| 61-12-02225 | 60" 2-DOOR | DH + 3 1/2" | 2XDW+1-1/4" | 6' 9 3/4" | 59 1/4" | \$44.00 |
| 61-12-02226 | 72" 2-DOOR | DH + 3 1/2" | 2XDW+1-1/4" | 6' 9 3/4" | 71 1/4" | \$48.00 |

2222 ALUMINUM TRACK IN WOOD HEADER

| CODE | DESCRIPTION | ROUGH OPENING | | FINISHED OPENING | | EACH |
|-------------|-------------|---------------|-------------|------------------|---------|---------|
| | | HEIGHT | WIDTH | HEIGHT | WIDTH | |
| 61-12-00224 | 48" 2-DOOR | 6' 10 1/2" | 2XDW+1-1/4" | 6' 8 5/8" | 47 1/4" | \$46.00 |
| 61-12-00225 | 60" 2-DOOR | 6' 10 1/2" | 2XDW+1-1/4" | 6' 8 5/8" | 59 1/4" | \$52.00 |
| 61-12-00226 | 72" 2-DOOR | 6' 10 1/2" | 2XDW+1-1/4" | 6' 8 5/8" | 71 1/4" | \$60.00 |
| 61-12-00228 | 96" 4-DOOR | 6' 10 1/2" | 4XDW+1/2" | 6' 8 5/8" | 94 1/2" | \$84.00 |

* PRICES ARE SUBJECT TO CHANGE WITHOUT NOTICE *



15 Kenton Lands Road, Erlanger, Kentucky 41018 - Ph# 859-341-5500 - Fax# 859-341-4115

1500 POCKET DOOR FRAMES-K.D.



SELF ADJUSTING FLOOR ANCHORS

Long vertical fingers slide into split studs - allowing for floor settling without disturbing horizontal alignment of header and track. Anchors can be nailed, screwed or cemented to floor.

STEEL WRAPPED UPRIGHT STUDS

Split jamb and studs uprights have full zinc plated steel sides and backs to give maximum rigidity for wall material and to restrict accidental nail penetration. Slots on split stud edges allow easy nailing of jamb stock.

REMOVABLE TRACK

Track has keyhole attaching point slots allowing easy removal without tearing out walls. Box design prevents rollers from jumping track. Heavy walled aluminum track is precision extruded for smooth operation. Convex rail track design provides single point hanger wheel contact for low roll resistance and dust traps on both sides of rails allow hangers to operate freely when dust builds up.

TRICYCLE HANGERS

Unique three wheel design ensures all wheels carry door weight equally. Smooth rolling balanced wheels offer minimum friction riding on convex track rails. "Flip-of-a-clip" separates wheels from hanger plate for easy door installation/removal. Standard **1120 hangers** are tested for doors weighing up to 125 lbs. [57 kg.] and **1125 heavy-duty ball bearing hangers** are tested for doors weighing up to 200 lbs. [91 kg.] each.

TESTED QUALITY

Johnson pocket door frames are the only pocket door frames INDEPENDENTLY tested to ANSI standards.

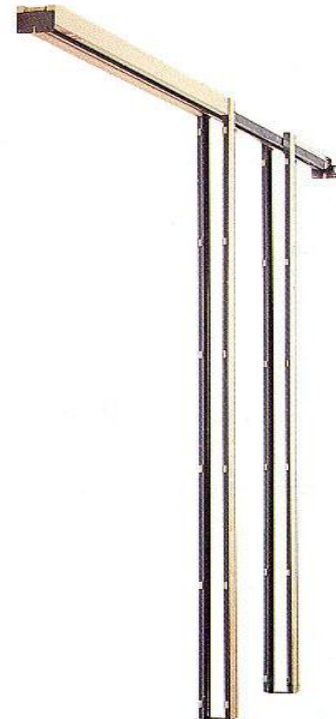

ASSEMBLED FRAME

| CODE | SIZE | EACH |
|-------------|---------------|----------|
| 61-15-01520 | 2' 0" X 6' 8" | \$128.00 |
| 61-15-01524 | 2' 4" X 6' 8" | \$128.00 |
| 61-15-01526 | 2' 6" X 6' 8" | \$128.00 |
| 61-15-01530 | 3' 0" X 6' 8" | \$128.00 |

| CODE | DESCRIPTION | EACH |
|-------------|--|---------|
| 61-15-00026 | CONVERGING KIT # 1555 FOR POCKET DOORS | \$10.00 |

* PRICES ARE SUBJECT TO CHANGE WITHOUT NOTICE *



2710 PRE-FABRICATED POCKET DOOR FRAMES

Designed for use in standard 4-9/16" (115 mm) thick walls sheeted with drywall. Removable aluminum track with convex rails, rust resistant steel reinforced frame stiffener, jump proof three wheel hangers and self adjusting floor anchors. Plaster ground on frame accepts up to 1/2" (12mm) plaster board material or can be trimmed for 1/4" (6.3mm) paneling material. Horizontal members provide solid support for wall materials, and the center member is located at 48" (121.9cm) center for horizontal plaster board installations. Standard track and tricycle hangers are 111 Series, but for heavier doors, the 100 Series track and 1125 hanger combination is available for door up to 200lbs. (91kg.). An adjustable steel bracket on the header fastens directly to the rough stud at the opening side. This allows the finished jamb to be installed after rough construction is completed, preventing damage to finished materials.



| CODE | SIZE | EACH |
|-------------|---------------|----------|
| 61-15-00320 | 2' 0" X 6' 8" | \$126.00 |
| 61-15-00324 | 2' 4" X 6' 8" | \$138.00 |
| 61-15-00326 | 2' 6" X 6' 8" | \$142.00 |
| 61-15-00328 | 2' 8" X 6' 8" | \$148.00 |
| 61-15-00330 | 3' 0" X 6' 8" | \$152.00 |

* PRICES ARE SUBJECT TO CHANGE WITHOUT NOTICE *



15 Kenton Lands Road, Erlanger, Kentucky 41018 - Ph# 859-341-5500 - Fax# 859-341-4115

SLIDING DOOR HARDWARE

NO. 134 F-SLIDING DOOR HARDWARE
HEAVY DUTY FOR DOORS UP TO 125 POUNDS

| CODE | SIZE | EACH |
|-------------|------|----------|
| 61-12-01344 | 48" | \$84.00 |
| 61-12-01345 | 60" | \$98.00 |
| 61-12-01346 | 72" | \$110.00 |

PEEK PAK REPLACEMENT PARTS

| CODE | DESCRIPTION | EACH |
|-------------|---|---------|
| 61-15-01120 | # 1120 HANGER PEEK PAK | \$14.00 |
| 61-15-01501 | # 1500 POCKET DOOR HARDWARE PEEK PAK | \$24.00 |
| 61-12-16061 | # 1606 HINGE PEEK PAK | \$10.00 |
| 61-12-17031 | # 1703 HINGE PEEK PAK | \$8.00 |
| 61-12-17061 | # 1706 PIVOT SET PEEK PAK | \$7.00 |
| 61-12-18081 | # 1808 ALIGNER PEEK PAK | \$4.00 |
| 61-12-22161 | # 2216 HANGER PEEK PAK | \$7.00 |
| 61-12-21361 | # 2136 CARPET RISER PEEK PAK | \$4.00 |
| 61-12-22381 | # 2238 HANGER PEEK PAK | \$7.00 |
| 61-12-00300 | # 2135 BYPASS DOOR GUIDE PEEK PAK | \$6.00 |
| 61-12-22156 | # 2156 BYPASS DOOR GUIDE W/RISER PEEK PAK | \$8.00 |
| 61-15-00150 | # 150 EDGE PULL | \$11.00 |
| 61-15-00153 | # 15 US-3 PULL | \$4.00 |
| 61-12-21551 | # 2155 DOOR STOP | \$4.00 |

* PRICES ARE SUBJECT TO CHANGE WITHOUT NOTICE *



15 Kenton Lands Road, Erlanger, Kentucky 41018 - Ph# 859-341-5500 - Fax# 859-341-4115

| RC 1841 3 1/2" x 3 1/2" - 5/8" RADIUS | | | | |
|--|-------------|------------|------------------|-----------------------|
| Finish | Code | BOX | Hager | List per Hinge |
| US 26D – Brushed Chrome | 61-09-32050 | 100 | 30720 | \$6.00 |
| US 26 – Bright Chrome | 61-09-32053 | 100 | 30719 | \$6.00 |
| US 3 – Bright Brass | 61-09-32013 | 100 | 30718 | \$6.00 |
| US 2D – Dull Brass | 61-09-32010 | 100 | 27355 | \$4.00 |
| US 5A – Antique Brass | 61-09-32011 | 100 | 30724 ABA | \$6.00 |
| US 2CD – Brushed Chrome | 61-09-32008 | 100 | 76017 | \$5.00 |
| US 10B – Oil Rubbed Bronze | 61-09-32033 | 100 | 42004 10R | \$6.00 |
| US 15A – Antique Nickel | 61-09-32071 | 100 | 30842 AN | \$6.00 |
| US 15 – Satin Nickel | 61-09-32076 | 100 | 30727 | \$6.00 |
| US 3 LB -Light Brass | 61-09-32009 | 100 | 27360 | \$4.00 |

| 1446 Ball Catches | | | | |
|----------------------------|-------------|------------|------------------|------------------|
| Finish | Code | BOX | Hager | List EACH |
| US 3 – Bright Brass | 61-05-40413 | 50 | 51902 | \$20.00 |
| US 5A – Antique Brass | 61-05-40411 | 50 | 51903 ABA | \$20.00 |
| US 15 – Satin Nickel | 61-05-40476 | 50 | 36878 | \$20.00 |
| US 15A – Antique Nickel | 61-05-40471 | 50 | 36870 AN | \$20.00 |
| US 10B – Oil Rubbed Bronze | 61-05-40433 | 50 | 1446 10R | \$20.00 |
| US 26D – Brushed Chrome | 61-05-40453 | 50 | 55608 | \$20.00 |

| 1414 HEAD AND FOOT BOLTS | | | | |
|---------------------------------|-------------|------------|--------------|------------------|
| Finish | Code | BOX | Hager | List EACH |
| US 3 – Bright Brass | 61-05-41513 | | 51917 | \$46.00 |
| US 26D – Brushed Chrome | 61-05-41553 | | 55570 | \$46.00 |
| US 15 – Satin Nickel | 61-05-41576 | | 40830 | \$46.00 |

Prices are List Prices
Prices Subject to Change Without Notice



HINGES 4 " x 4 "

| RC 1841 4 " x 4 " - 5/8" RADIUS | | | | |
|--|-------------|------------|--------------|-----------------------|
| Finish | Code | BOX | Hager | List per Hinge |
| US 26D – Brushed Chrome | 61-09-42050 | 100 | 33307 | \$8.00 |
| US 2D – Dull Brass | 61-09-42010 | 100 | 27771 | \$5.00 |
| US 2CD – Brushed Chrome | 61-09-42008 | 100 | 76021 | \$8.00 |
| US 15 – Satin Nickel | 61-09-42076 | 100 | 32893 | \$8.00 |
| US 3 LB - Light Brass | 61-09-42009 | 100 | 27995 | \$5.00 |

| 1752 4 " x 4 " - 5/8"RADIUS x 5/8"RADIUS SPRING HINGE | | | | |
|--|-------------|------------|--------------|-----------------------|
| Finish | Code | BOX | Hager | List per Hinge |
| US 15 – Satin Nickel | 61-09-42676 | 40 | 30127 | \$46.00 |
| US 26D – Brushed Chrome | 61-09-42650 | 40 | 30018 | \$46.00 |
| US 3 – Bright Brass | 61-09-42613 | 40 | 29848 | \$46.00 |

| C813 FIBERGLASS DOOR HINGE | | | | |
|-----------------------------------|-------------|------------|--------------|-----------------------|
| Finish | Code | BOX | Hager | List per Hinge |
| US 2D – Dull Brass REVP4 | 61-09-43210 | 100 | 33232 | \$5.00 |
| US 2D – Dull Brass REVP3 | 61-09-43110 | 100 | 38249 | \$5.00 |

| 1817 4 " x 4 " - 5/8"RADIUS x SQUARE LEFT HAND | | | | |
|---|-------------|------------|--------------|-----------------------|
| Finish | Code | BOX | Hager | List per Hinge |
| US 26D – Brushed Chrome | 61-09-47150 | 100 | 70476 | \$8.00 |
| US 15 – Satin Nickel | 61-09-47176 | 100 | 70459 | \$8.00 |
| US 2D – Dull Brass | 61-09-47110 | 100 | 70403 | \$5.00 |

| 1816 4 " x 4 " - 5/8"RADIUS x SQUARE RIGHT HAND | | | | |
|--|-------------|------------|--------------|------------------------|
| Finish | Code | BOX | Hager | Price per Hinge |
| US 26D – Brushed Chrome | 61-09-47250 | 100 | 69134 | \$8.00 |
| US 15 – Satin Nickel | 61-09-47276 | 100 | 69140 | \$8.00 |
| US 2D – Dull Brass | 61-09-47210 | 100 | 69009 | \$5.00 |

Prices are List Prices

Prices Subject to Change Without Notice



PANIC DEVICE



SERIES 7301 PANIC DEVICE

- ◆ Underwriter's Laboratories Inc. Listed
- ◆ For use with Aluminum, Hollow Metal or Wood Doors
- ◆ Non-Handed, for LHRB or RHRB doors
- ◆ Latch bolt throw 5/8"
- ◆ Dogging by Hex Key in Touch Bar
- ◆ Aluminum Baked Enamel Finish
- ◆ Standard units for 36" or 48" door widths
- ◆ Can be used on 30" wide doors

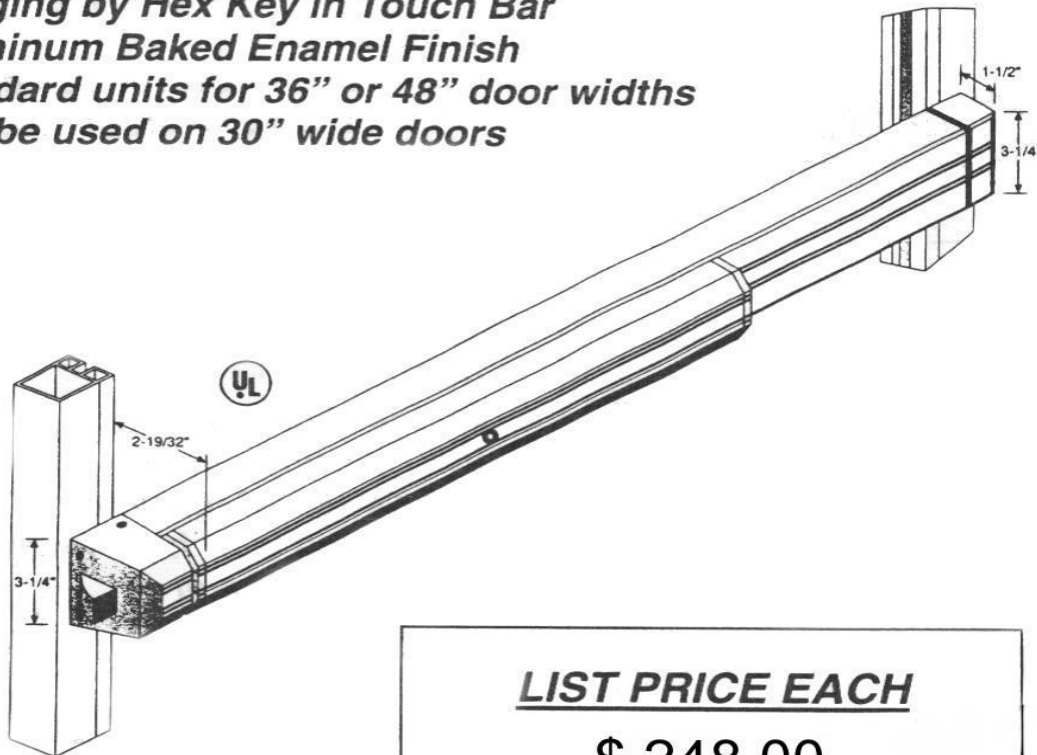

LIST PRICE EACH
\$ 248.00
CODE: 610740730

* PRICES ARE SUBJECT TO CHANGE WITHOUT NOTICE *



15 Kenton Lands Road, Erlanger, Kentucky 41018 - Ph# 859-341-5500 - Fax# 859-341-4115

DOOR CLOSER

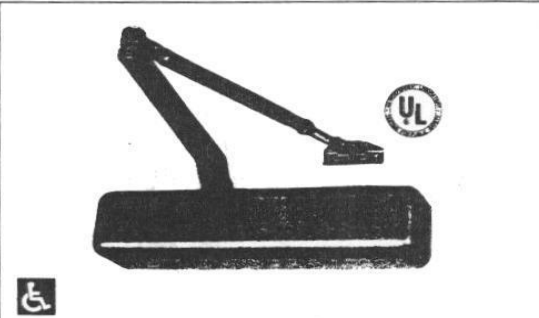
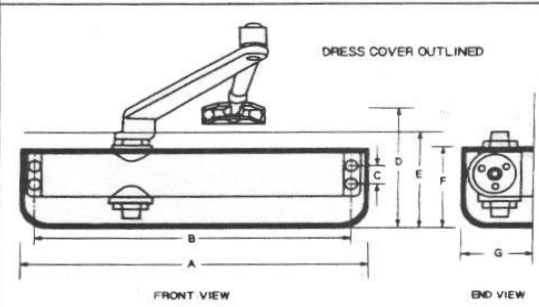

SERIES 9001 CLOSER

| DESCRIPTION | MODEL NUMBER | |
|---------------------------------|---------------|----------|
| | 9001 and 9003 | |
| Length of Closer | A | 12-1/8" |
| Horizontal Mounting Holes | B | 11-3/32" |
| Vertical Mounting Holes | C | 3/4" |
| Overall Height | D | 4-9/16" |
| Top of Door to Bottom of Closer | E | 3-5/16" |
| Height of Closer | F | 2-13/16" |
| Projection from Door | G | 2-9/16" |

- ◆ *Underwriter's Laboratories Inc. Listed*
- ◆ *Aluminum Baked Enamel Finish*
- ◆ *Two Speed Control Valves*
- ◆ *Universal Application: Non-Handed for standard, top jamb or parallel arm installation*
- ◆ *Rack & Pinion mechanism contained in cast aluminum housing*
- ◆ *Stable Hydraulic door check fluid for any climate operation and constant lubrication*
- ◆ *Furnished with high impact PVC dress cover*

LIST PRICE EACH
\$ 120.00
CODE: 610740930

* PRICES ARE SUBJECT TO CHANGE WITHOUT NOTICE *